

ZENMUSE X4S

User Manual V1.0

2016.12

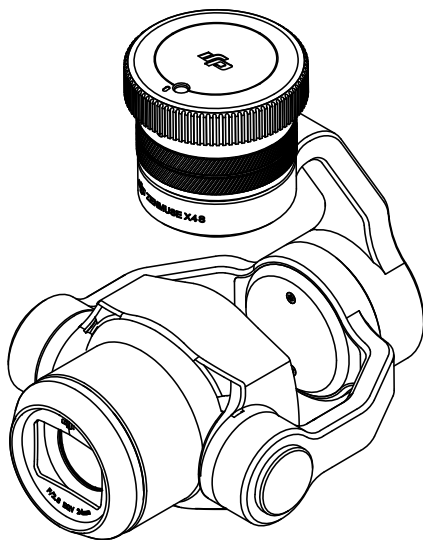

Searching for Keywords

Search for keywords such as “battery” and “install” to find a topic. If you are using Adobe Acrobat Reader to read this document, press Ctrl+F on Windows or Command+F on Mac to begin a search.

Navigating to a Topic

View a complete list of topics in the table of contents.

Printing this Document

This document supports high resolution printing.

Read Before the First Flight

Legends

 Warning

 Important

 Hints and Tips

 Reference

Using this manual

Read the following documents before using the ZENMUSE™ X4S.

- 1.Zenmuse X4S Quick Start Guide
- 2.Zenmuse X4S User Manual

We recommend reading the Zenmuse X4S Quick Start Guide, especially its Disclaimer and Safety sections, to get familiar with all parts of the Zenmuse X4S. Refer to this Zenmuse X4S User Manual for detailed information.

Getting more information

Visit the following webpage for more information about the Zenmuse X4S.

<http://www.dji.com/zenmuse-x4s>



Contents

Read Before the First Flight	2
Legends	2
Using this manual	2
Getting more information	2
Contents	3
Product Profile	4
Introduction	4
In the Box	4
Overview	4
Installation	5
Read the information below before setting up your Zenmuse X4S	5
Supported Devices	5
Mounting the Zenmuse X4S to the aircraft	5
Mounting the Zenmuse X4S to the Inspire 2	5
Mechanical Range	6
Using the Remote Controller	6
DJI GO 4 App	7
Downloading	7
Launching the DJI GO 4 app	7
Camera Operation	8
Touch Interface	8
Basic Shooting	8
Taking Photos	8
Recording	9
Advanced Settings	9
Exposure Mode	9
Photo Styles	9
White Balance	10
List of Settings	10
Managing your Photos and Videos	11
Playback	11
Update Firmware	12
Method 1: Using the DJI Assistant 2	12
Method 2: Using the DJI GO 4 App	12
Appendix	12
Specifications	12

Product Profile

Introduction

Featuring a 1-inch CMOS sensor and large pixels measuring 2.4 μ m per pixel, the Zenmuse X4S is capable of capturing 20 megapixel stills and capturing 11.6 stops of dynamic range. It can record 4K/60 H.264 and 4K/30 H.265 videos at a 100Mbps bitrate. A variety of shooting modes are available for a better shooting experience. 14 image Burst and AEB is available.

The Zenmuse X4S has an 8.8mm/F2.8-11 lens, which is compact with low distortion and a field of view of 84°.

When mounted on the INSPIRE™ 2, the 3-axis gimbal provides a stable platform for the camera to get clear shots even during rapid maneuvering. The gimbal tilts the camera across a -130° to +40° pitch angle and pans \pm 320° in both directions. Live HD video from the camera is streamed to the DJI GO™ 4 app.

In the Box

Check that all of the following items are in your package. If any item is missing, please contact DJI or your local dealer.

Zenmuse X4S x1

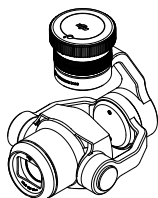

Document



Quick Start Guide

Overview

Zenmuse X4S

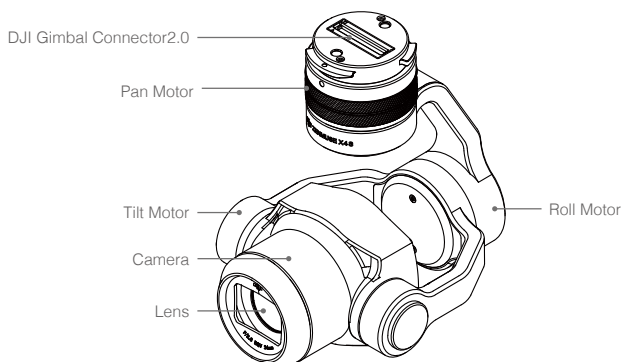

Installation

Read the information below before setting up your Zenmuse X4S

Supported Devices

The Zenmuse X4S can be attached to the following device, and will be compatible with other DJI devices in the future.

DJI Inspire 2

Mounting the Zenmuse X4S to the aircraft

Mounting the Zenmuse X4S to the Inspire 2

Power off the aircraft before installation.

1. Remove the camera body cap from the Zenmuse X4S.

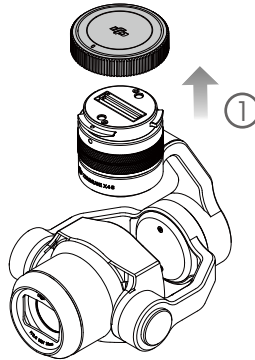

2. Press the gimbal and the camera release button on the Inspire 2. Rotate to remove the Gimbal Cap from the Inspire 2.
3. Align the white dot on the gimbal with the red dot on the Inspire 2 and insert the gimbal.
4. Rotate the Gimbal Lock to the locked position (red dots aligned).

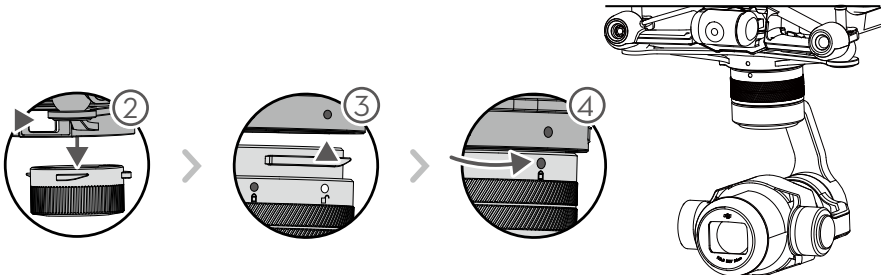

- ⚠ • Protect the Gimbal Connector 2.0 at all times.
- Always ensure that the Gimbal Connector 2.0 on the Inspire 2 is in the right position when mounting, otherwise the camera will not mount.
- DO NOT detach the Zenmuse X4S when the aircraft is powered on.

Mechanical Range

The 3-axis gimbal provides an incredibly stable and mobile platform for the camera system to capture completely smooth images and videos. The gimbal can tilt the camera up to 170 degrees, pan 320 degrees and roll 20 degrees in either direction.

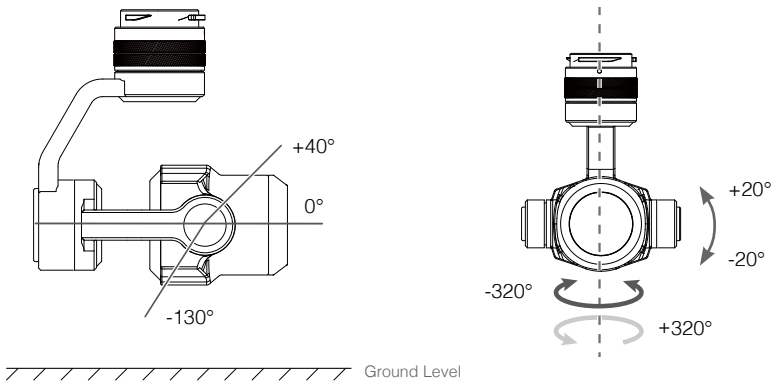

- ⚠ • Take off from flat, open ground and protect the gimbal at all times.

Using the Remote Controller

Press the Shutter Button to capture photos or the Record Button to record videos. Adjust the camera's tilt using the left dial. Turn the right dial to adjust camera settings.

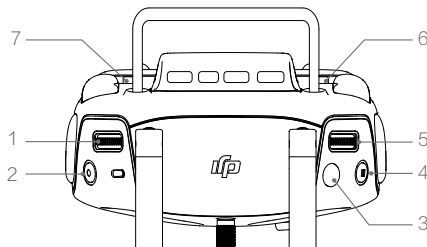

1. Left Dial

Scroll this dial to control tilt the gimbal. Scroll this dial while pressing C1 to control yaw the gimbal; Scroll this dia while pressing C2 to control tilt of the FPV.

2. Record Button

Press once to start video recording. Press again to stop recording.

3. Shutter Button

Press to take a photo. If burst mode is selected, the set number of photos will be taken with one press.

4. Intelligent Flight Pause Button

Press once to exit from TapFly™, ActiveTrack™ and Advanced modes.

5. Right Dial

Press once and then scroll to set camera settings. Re-activate this function after 10s' free of operation.

6. C2 Button

Set in DJI GO 4 app.

7. C1 Button

Set in DJI GO 4 app.

DJI GO 4 App

Downloading

Search for "DJI GO 4" in the App Store, or download at www.dji.com.

Launching the DJI GO 4 app

1. Power on the remote controller and the aircraft.
2. Connect the remote controller and your mobile device via a USB cable.

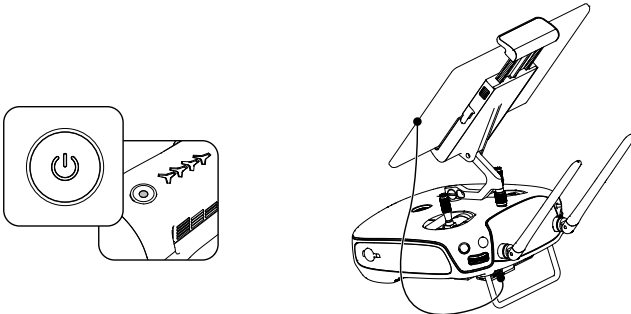

3. Launch the DJI GO 4 app after connecting, and the live HD video stream will begin.

Camera Operation

Touch Interface

The touch interface can be used for capturing photos, recording videos and playback. Professional photography configurations are also available.

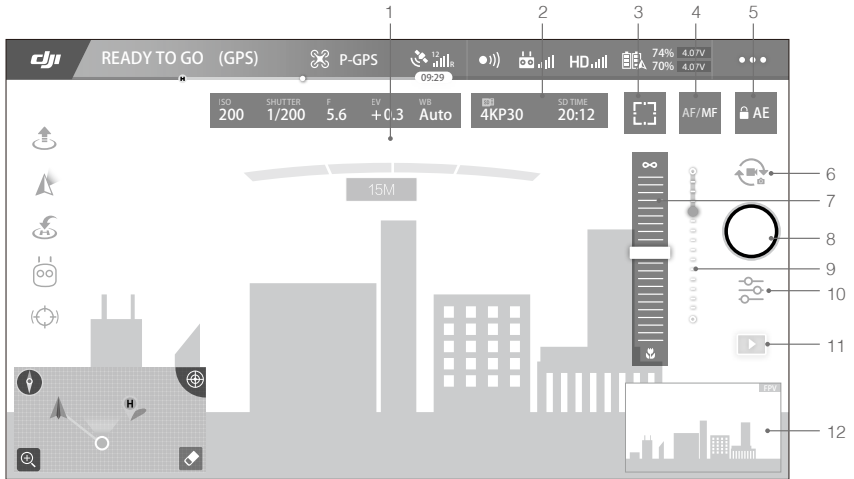

1. Live HD Video
2. Current Camera Settings
3. Spot Metering/ Focus Switch
4. AF/MF
5. AE Lock
6. Shutter/Record Switch
7. MF Adjustment (in MF mode)
8. Shutter/Record
9. Gimbal Slider
10. Photography Configurations and Parameter Settings
11. Playback
12. FPV(Tablets only)

Basic Shooting

Insert supported Micro SD card into the Inspire 2 to activate still capturing and video recording. Refer to the Specifications for detailed information of supported Micro SD cards.

Taking Photos

You can start capturing in the following two ways:

DJI GO 4 App: Tap the Shutter/Record Switch to select Shutter . Tap the button to take photos.

Remote Controller: Press the Shutter Button on the Remote Controller.

Single shooting is set by default. Choose from one of the shooting modes via the DJI GO 4 app. Tap -> -> Photo

1. Multiple Mode

Take 3, 5, 7, 10, or 14 shots in a row.

2. AEB (Auto Exposure Bracketing)



Take 3 or 5 bracketed frames with $\pm 0.7\text{EV}$ steps for exposure compensation.

3. Timed Shot

Take photos in 2, 3, 5, 7, 10, 15, 20, 30 or 60 second intervals.

Recording

You can start recording in the following two ways:

DJI GO 4 App: Tap Shutter/Record Switch button to activate video recording mode , and then tap the button . Tap once to start recording video, then tap again to stop recording. The recording time length will be displayed below the Shutter/Record button.

Remote Controller: You can also press the Video Recording Button on the remote controller, which has the same function.

Advanced Settings



Exposure Mode

Tap , to choose from the exposure modes, including: Auto, Aperture Priority(A), Shutter Priority(S) M(Manual Exposure). By setting different EV values, a variety of exposure can be achieved in AUTO, S and A mode. ISO values can be set in all modes. When the aircraft is in P/S/A mode, you can choose to set the ISO automatically or manually.



1. Auto

The shutter speed and aperture are set automatically to obtain the correct exposure.

2. S(Shutter Priority)

Tap ->-> S. Set your desired shutter speed, while the camera chooses the aperture automatically. This mode is ideal for freezing action, creating motion blur or low-light shots.



3. A(Aperture Priority)

Tap ->-> A. Set your required aperture, while the camera chooses the shutter speed automatically. This mode provides a wider depth of field and can be used to blur out backgrounds.

4. M(Manual Exposure)



In manual mode, set aperture, shutter speed and ISO based on actual needs.

Photo Styles

Select different styles to capture photos with different sharpnesses, contrast levels and saturation. Tap ->->Style.

1. Standard: A general-purpose style for most scenes.
2. Landscape: The camera will focus on as much of the scene as possible using a large depth of field.
3. Soft: Suitable for scenes with natural or soft colors.
4. Custom: Sharpness, contrast and saturation can be set separately.
 - Sharpness: The photos will be softer with lower values and clearer with higher values.
 - Contrast: Increasing the value will make images more dramatic.
 - Saturation: Colors will lighten at lower values and darken at higher values.

White Balance

White balance (WB) is the process of removing unrealistic color casts. Correcting white balance can help avoid the color casts, thereby improving photos under a wider range of lighting conditions. White balance can be either set into a fixed value or a dynamic value automatically. Tap "  "->  ->Whit Balance.

1. Auto (AWB)

The camera adjusts the white balance automatically.

2. Sunny / Cloudy / Incandescent / Neon

Choose one of these modes if natural-looking colors cannot be achieved through photo styles.

3. Custom

Set a value to compensate for a specific light source.

List of Settings

Photo	
Still Photography Modes	Single Shot, Multiple(3/5/7/10/14frames), AEB(3/5bracketed frames at 0.7EV bias), Timed Shot(2/3/5/7/10/15/20/30/60s)
Image Size	3:2, 4:3, 16:9
Image Format	DNG,JPEG,DNG+JEPG
White Balance	Auto(AWB), Sunny, Cloudy, Incandescent, Neon, Custom(2000K~10000K)
Style	Standard, Landscape, Soft, Custom (Sharpness/Contrast/ Saturation)
Color	Ordinary, TrueColor, D-Cinelike, D-Log, Film Looks.
Video	
	H.264
	C4K: 4096×2160 23.976/24/25/29.97/47.95/50/59.94p @100Mbps
	4K: 3840×2160 23.976/24/25/29.97/47.95/50/59.94p @100Mbps
	2.7K: 2720×1530 23.976/24/25/29.97p @80Mbps 47.95/50/59.94p @100Mbps
	FHD: 1920×1080 23.976/24/25/29.97p @60Mbps 47.95/50/59.94p @80Mbps 119.88p @100Mbps
Video Recording Modes	H.265
	C4K: 4096×2160 23.976/24/25/29.97p @100Mbps
	4K: 3840×2160 23.976/24/25/29.97p @100Mbps
	2.7K: 2720×1530 23.976/24/25/29.97p @65Mbps 47.95/50/59.94p @80Mbps
	FHD: 1920×1080 23.976/24/25/29.97p @50Mbps 47.95/50/59.94p @65Mbps 119.88p @100Mbps
Video Format	MP4/ MOV (H.264/ H.265)
NTSC/PAL	PAL, NTSC
White Balance	Auto(AWB), Sunny, Cloudy, Incandescent, Neon, Custom(2000K~10000K)
Style	Standard, Landscape, Soft, Custom (Sharpness/Contrast/ Saturation)

Specifications

Center Point	None, Circle, Cross, Narrow Cross, Square (No Center Point), Square (w.Center Point), Bracket(No Center Point), Bracket (w. Center Point)
Anti-Flicker	Auto, 50Hz,60Hz
Grid	None, Grid Lines, Grid+Diagonals
File Index Mode	Reset, Continuous
Smart Arm LEDs	Off, Front LEDs Auto Turn Off, Turn off Back LEDs, Turn off Arm LEDs
Other	Histogram, Video Caption, Over Exposure Warning, AF Focus Assistant, MF Focus Assistant, Lens Profile, Calibration*, Reset Camera Settings, Format SD Card

* Manual lens calibration is required when used for the first time. Incorrect calibration will result in an inability to focus to infinite. Calibrate camera in the camera setting page in the DJI GO app.

Managing your Photos and Videos

Playback

You can playback your videos and photos in the following ways:

DJI GO 4 App: Tap the playback button in the DJI GO 4 app  to review photos and videos that you have captured. Press the same button again to return to capture images.

 Photos and videos are saved in the Micro SD card.

Update Firmware

The firmware of the Zenmuse X4S should be updated together with the Inspire 2. Using an Inspire 2 with the Zenmuse X4S mounted as an example.

Method 1: Using the DJI Assistant™ 2

1. Power on the Intelligent Flight Battery, and toggle the USB Mode Switch down.
2. Connect the Inspire 2 and the PC via the USB cable (with double A ports).
3. Launch DJI Assistant 2 and login with a DJI account.
4. Click Inspire 2 and the firmware update button.
5. Select the firmware version required.
6. DJI Assistant 2 will download and upgrade the firmware automatically.
7. Restart the aircraft after the firmware upgrade is complete.

Method 2: Using the DJI GO 4 App

1. Power on the Intelligent Flight Battery, and toggle the USB Mode Switch up.
2. Connect the aircraft and your mobile device via an appropriate USB cable.
3. Follow the on-screen instructions in the DJI GO 4 app to upgrade. Connect to the Internet when downloading firmware.
4. Restart the aircraft after the firmware upgrade is complete.



- During update, the aircraft will beep steadily. Then the beep will alternate between a longer beep and a quick double beep once the update is complete. Restart the aircraft after the firmware update is complete.
- If the warning sound turns into a long beep, retry the update.
- The battery level should be above 30% for the firmware update process.
- When using the DJI GO 4 app to update, you may disconnect the aircraft and the mobile device once the update is more than 30% completed. No Internet connection is required.

Appendix

Specifications

General

Name	Zenmuse X4S
Dimensions	125 mm (W) × 100 mm (H) × 80 mm (D)
Weight	Approx. 253 g
Operating Temperature Range	-4° to 104°F (-20° to 40°C)
Storage Temperature	-4° to 140°F (-20° to 60°C)

Camera

Lens	F/2.8-11, 8.8mm(35mm format equivalent: 24mm)
------	---

Sensors	1 inch CMOS Sensor
Effective Pixels	20MP
Image Size	3:2, 4:3, 16:9
ISO Range	Photo:100-25600 Video:100-6400
Shutter Speed	Mechanical Shutter Speed: 8 – 1/2000 s Electric Shutter Speed:1/2000 s -1/8000 s
FOV	84°
Still Photography Modes	Single Shot, Multiple(3/5/7/10/14frames), AEB(3/5bracketed frames at 0.7EV bias), Timed Shot(2/3/5/7/10/15/20/30/60s)
Video Recording Modes	<p>H.264</p> <p>C4K: 4096×2160 23.976/24/25/29.97/47.95/50/59.94p @100Mbps 4K: 3840×2160 23.976/24/25/29.97/47.95/50/59.94p @100Mbps 2.7K: 2720×1530 23.976/24/25/29.97p @80Mbps 47.95/50/59.94p @100Mbps FHD: 1920×1080 23.976/24/25/29.97p @60Mbps 47.95/50/59.94p @80Mbps 119.88p @100Mbps</p> <p>H.265</p> <p>C4K: 4096×2160 23.976/24/25/29.97p @100Mbps 4K: 3840×2160 23.976/24/25/29.97p @100Mbps 2.7K: 2720×1530 23.976/24/25/29.97p @65Mbps 47.95/50/59.94p @80Mbps FHD: 1920×1080 23.976/24/25/29.97p @50Mbps 47.95/50/59.94p @65Mbps 119.88p @100Mbps</p>
Max. Bitrate	100 Mbps
Image Format	DNG, JPEG, DNG+JPEG
Video Format	MP4/ MOV (H.264/ H.265)
Supported Micro SD Cards(Insert into the aircraft)	Sandisk Extreme 32GB UHS-3 MICROSDHC Sandisk Extreme 64GB UHS-3 MICROSDXC Panasonic 32GB UHS-3 MicroSDHC Panasonic 64GB UHS-3 MicroSDXC Samsung PRO 32GB UHS-3 MicroSDHC Samsung PRO 64GB UHS-3 MicroSDXC Samsung PRO 128GB UHS-3 MicroSDXC
Gimbal	
Angular Vibration Range	±0.01°
Mount	Detachable
Controllable Range	Tilt: -130° to +40°;Pan: ±320° ;Roll: ±20°
Max Controllable Speed	Tilt: 180° / s;Pan: 270° / s;Roll: 180° / s

Zenmuse X4S does not support file storage. Please save your photos and videos in the Micro SD card inserted in the aircraft.

DJI Support:
<http://www.dji.com/support>

This content is subject to change.

Download the latest version from
<http://www.dji.com/zenmuse-x4s>

If you have any questions about this document, please contact DJI by sending a message to DocSupport@dji.com.

© 2016 DJI. All Rights Reserved.